

*Full Length Research Paper*

# Street children's resistance to street removal interventions

Melody Chisanga

Department of Post Graduate Studies, Faculty of Development Studies, University of Lusaka, Lusaka, Zambia.

Received 27 November, 2025; Accepted 5 February, 2026

**This research aimed to determine the factors contributing to street children's resistance to street-removal interventions. Interviews were conducted with children living on the streets, former street children, and guardians. In addition, caregivers in child-care facilities, also known as centers, provided insights through questionnaires. The study concluded that poverty, family conflict, peer pressure, the desire for money, abuse, and the need to experience freedom were the main factors contributing to children's decision to live on the streets. Furthermore, poverty, family conflict, mistreatment, the need for money, peer pressure, addiction-related needs, uncondusive conditions in child-care facilities, strict rules, misconduct, and inadequate resources contributed to children returning to the streets during or after the reintegration process. The study recommended increased collaboration among organizations working with street children, greater resource allocation to intervention programs by the government and its development partners, and the development of policy frameworks to guide programs targeting street children. It also emphasized the need for interventions that address both the root causes of street involvement and the factors that drive children back to the streets during and after reintegration.**

**Key words:** Street children, interventions, child care facility, Lusaka, reintegration.

## INTRODUCTION

A street child, as defined by the United Nations Children's Fund (UNICEF), is any girl or boy who has not reached adulthood, for whom the street is the habitual place of residence or source of livelihood, and who is inadequately protected or supervised by responsible adults. The phenomenon of street children has been driven by various factors, including poverty, hunger, lack of education, unemployment, HIV/AIDS, the death of parents or guardians, unsupportive relatives, family breakdown, and the need to supplement household income (Ministry of Community Development and Social Services and Ministry of Sports, Youth and Child Development, 2006, as cited in

Bruce, 2014). Determining whether the number of street children has increased over time is challenging due to difficulties in quantifying this population. Nevertheless, existing research estimates indicate that the number of street children in Zambia remains high. A UNICEF report in 1996 estimated approximately 75,000 street children, an increase from a lower estimate of 35,000 in 1991. More recent figures reported about 13,200 street children in 2014 (Chiwaula et al., 2014). While living on the streets, children face numerous challenges, including, but not limited to, resentment and ridicule from the general public, insecurity, oppression, disease, exploitation, poverty,

E-mail: [melody.chisanga@yahoo.com](mailto:melody.chisanga@yahoo.com). Tel: +260975841737.

Author(s) agree that this article remain permanently open access under the terms of the [Creative Commons Attribution License 4.0 International License](https://creativecommons.org/licenses/by/4.0/)

sexual abuse, and torture (Hai, 2014). These conditions prompted the government and other stakeholders to implement interventions aimed at removing children from the streets. One of the most prominent interventions has been the establishment of child-care facilities, which provide access to basic needs such as physical security, medical care, nutrition, counseling, education, recreation, and spiritual support. By 2007, approximately 4,592 children were undergoing rehabilitation in various residential institutions across Zambia (Mtonga, 2011).

Lusaka, the capital city of Zambia, serves as the country's main economic and administrative hub and attracts significant rural–urban migration in search of better livelihood opportunities. Despite this status, the city experiences substantial economic disparities and is characterized by high levels of unemployment and poverty, with the majority of residents relying on the informal sector for survival (Zambia Statistical Agency and United Nations Economic Commission for Africa, 2022). Although the exact period when the street children phenomenon began in Lusaka and Zambia more broadly is unclear, it became particularly pronounced in the early 1990s (Strobbe et al., 2013). This increase was largely driven by the HIV/AIDS pandemic, which resulted in a large number of orphans without adequate care (Guest, 2003). During this period, Zambia lacked a comprehensive national strategy to address HIV/AIDS and its socio-economic consequences, leaving many orphaned and vulnerable children with limited support and increasing their likelihood of resorting to street life for survival. By 2003, approximately 70% of Lusaka's street children population was double orphans. In addition, Lusaka attracted street children from other provinces due to the economic opportunities available in the city (Guest, 2003).

Several organizations, including SOS Children's Villages, the Zambia Red Cross Society, Fountain of Hope, City of Hope, Development Aid from People to People (DAPP), Jesus Cares Ministries, and UNICEF, have been actively involved in supporting orphans and vulnerable children through various interventions. These interventions include empowering families caring for vulnerable children to prevent street migration, operating drop-in centers that provide food, clothing, and temporary shelter, as well as offering skills training, health care, education, counseling, and spiritual guidance (National assembly of Zambia, 2006). However, evidence indicates that some street children resist these interventions aimed at removing them from the streets. Consequently, this research focuses on identifying the factors contributing to street children's resistance to street-removal interventions.

### Statement of the problem

There is a persistently high number of children on the street. Musika (2018) as cited in UNICEF (2021) highlighted that in spite the various interventions that have been

put in place, there still remains the challenge of an increase in the number of street children in Zambia. This has consequently affected the progress in the removal of street children, which as of 2018 stood at 2000 in Lusaka (Musika, 2018 as cited in UNICEF (2021)). Despite the interventions in place, children resort to the streets, remain on the streets, or move back to the streets as opposed to being in childcare facilities, home with their families, or other facilities and programs designed to take them off the streets. Therefore, this research is set to explore factors contributing to children's resistance to interventions as a cardinal component of addressing the problem of a high number of street children, along with the economic and social challenges that arise from the situation.

### Research objectives

The main research objective for this study was to determine the factors contributing to street children's resistance to interventions to remove them from the streets of Lusaka. The specific research objects under this were:

- 1) To assess factors that make street children prefer the streets to reintegration
- 2) To explore factors that have made current interventions ineffective in removing children from the streets.
- 3) To determine factors that would ensure effectiveness of interventions in removing children from the streets.

## LITERATURE REVIEW

### Empirical review

#### ***Factors contributing to the ineffectiveness of applied interventions***

In Uganda, an organization focusing on service provision, strategic incubation, and policy advocacy reported that the use of brutal tactics to remove street children not only prolonged and perpetuated their problems but also denied them access to basic human rights. The report further indicated that NGO shelters and residential services for street children often perpetuated violence by concentrating children in poorly managed facilities (De Benítez, 2007). Similarly, in Ethiopia, placing street children in institutional care for rehabilitation through education and skills training programs was found to be ineffective due to the persistence of underlying factors driving children to street life. The studies noted that institutional placement did not yield positive outcomes in encouraging children to return to conventional childhood activities such as schooling and play. This was largely because these children had developed alternative perceptions of childhood based on their lived experiences. The research also highlighted that

removal-oriented approaches tended to adopt a universalized concept of childhood, paying limited attention to local contexts, children's competencies, and their potential contributions to their families and communities (Aptekar and Heinonen, 2003). Research by Scanlon et al. (1998) further showed that many NGOs implemented outreach programs that primarily provided food and medical support, and less frequently offered educational, psychological, and legal services. This pattern was also observed in Ethiopia, where food distribution for street children was predominant, largely because funding for food-related interventions was easier to secure (Aptekar and Heinonen, 2003).

In Zambia, following the introduction of the street children rehabilitation program in 2006, which trained approximately 1,200 children over a two-year period, it was observed that some beneficiaries returned to the streets shortly after completing the program. Many cited their inability to generate income using the skills acquired, with only a few successfully utilizing the training provided. The program was found to lack a clear exit strategy and failed to promote independence or provide adequate entrepreneurial skills to the children (Integrated Regional Information Networks [IRIN], 2008). Similarly, Mtonga (2011) reported that out of 453 youths enrolled in the Zambia National Service (ZNS) street children rehabilitation program, 93 (21%) returned to street life is a trend also observed in other care institutions. In South Africa, Mokomane and Makoe (2015) likewise found that care-focused interventions addressing only immediate needs such as food and basic health care, alongside welfare-based approaches, were criticized for failing to address the broader, interconnected factors shaping the lives of street children.

### ***Factors that propagate resistance***

In Zimbabwe, it was found that street children avoided welfare organizations because they feared being forced back to their families, which would compromise their freedom. Instead, they often pretended to cooperate with organizations to obtain specific benefits without a genuine commitment to reintegration (Aptekar and Heinonen, 2003). These fears may therefore be a significant factor contributing to children's resistance to interventions. In Ghana, some street children expressed aspirations to support themselves and maximize their savings, pursue stable jobs, and continue their education. However, they were concerned about losing their street-based income if they engaged in these activities (Korboe, 1996; United Nations Centre for Human Settlements [UNCHS], 2000). Similarly, in Ethiopia, it was observed that once street children experienced the freedom of street life, it was difficult for them to adapt to other lifestyles (Aptekar and Heinonen, 2003). Taylor et al. (2004) further concluded that street children often lacked the ability to define and pursue coherent goals, which influenced their reluctance

to engage in structured programs. A study by Ogunkan and Fawole (2020) explored the push-pull dynamics that compel children to live on the streets, highlighting poverty, family discord, abuse, and neglect as prominent push factors. Pull factors included perceived freedom and opportunities to earn money, reflecting similar issues observed in Zambia and other contexts. In Zambia, the Fountain of Hope organization faced significant challenges reintegrating street children into families or schools, sometimes concluding that certain children were "beyond help" and returning to the streets, particularly when promises made by the centers regarding provisions were not fulfilled (Guest, 2003). Statistics indicated that 40% of street children admitted to Fountain of Hope eventually returned to the streets (Phiri, 2015).

### ***Factors recommended for effective interventions***

In Iran, Zarezadeh (2013) highlighted various strategies implemented by the government and NGOs to address the issue of street children. These strategies included establishing centers for education and the transfer of technical and professional skills, providing shelter and care for children, organizing conferences and workshops, and maintaining contact with the families of street children. Preventive and control measures also involved support from religious institutions, as well as economic, social, and cultural assistance directed toward the families of street children. Additionally, policies addressing child labor and social insurance were introduced to support the welfare of street children. In Brazil, rehabilitation was recommended as an integral component of successful interventions for street children who abuse drugs. In Cambodia, an NGO emphasized the importance of stakeholder participation and the provision of guaranteed resources for programs (De Benitez, 2007). In Nigeria, research by Adebiyi et al. (2008) identified the lack of recreational facilities as a factor contributing to the emergence of street children. The study recommended that prevention programs consider this factor and incorporate strategies to strengthen family units.

### ***Theoretical framework***

For this study, the capabilities theory, Cosgrave's matrix of street children, and dependency theory were employed. The Capabilities Theory was applied to analyze whether one of the factors contributing to street children's resistance was that interventions failed to enhance or reflect their capabilities, or did not provide the type of support they sought. The Dependency Theory was used to examine whether institutions were self-sufficient and capable of meeting the demands of their programs, and to determine whether organizational dependence on external support contributed to street children's resistance to interventions. Cosgrave's Matrix was employed to assess

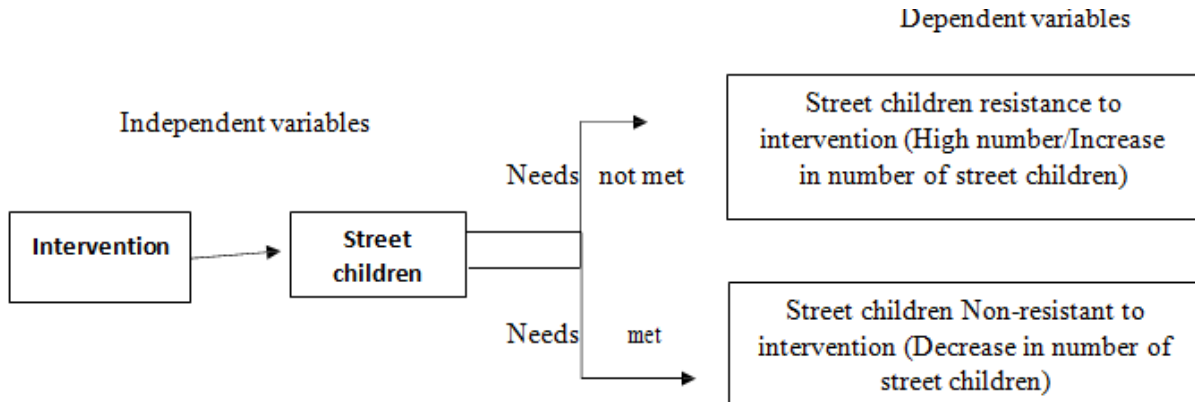

Figure 1. Conceptual framework.

whether the various programs provided by institutions were appropriate for street children at different stages of their development, and whether the timing or nature of programming influenced their resistance to removal interventions.

### Conceptual framework

The independent variables in this study are the street children themselves and the interventions implemented by the government and various stakeholders. These interventions may include, among others, outreach programs, drop-in centers, residential institutions, skills training centers, foster care, and feeding programs. The dependent variables are the resistance of street children to interventions and the number of street children, both of which are influenced by the extent to which interventions meet the needs of street children. Figure 1 presents the conceptual framework.

### MATERIALS AND METHODS

The approach used for this study was a mixed-methods approach, incorporating both qualitative and quantitative methods, with a greater emphasis on qualitative research. The research design employed was an embedded mixed-methods research design. Data were collected through questionnaires, individual interviews, focus group discussions, and observation schedules. Caregivers from organizations working with street children, specifically Fountain of Hope and Mtunzi Children's Home, were interviewed and responded to questionnaires. Former street children in institutional care under these organizations were also interviewed. Additionally, guardians whose children benefited from institutional care services at Fountain of Hope were interviewed, along with their children. Street children living on the streets of the Lusaka Central Business District were also interviewed, as were former street children who had been reintegrated into the community. The interviews were semi-structured, ensuring that participants were asked the same questions while allowing flexibility for participants to respond in their own way. Children living on the streets of Lusaka and those in institutional care at Fountain of Hope also participated in focus group discussions.

The researcher conducted observations of the living conditions in the institutional care centers at Fountain of Hope and Mtunzi Children's Home. These three methods of data collection were selected as they were best suited to answer the research questions and allowed for triangulation, thereby improving the validity of the findings. Individual interviews facilitated effective communication between the researcher and participants, enabling the collection of in-depth information. They also allowed participants to clarify questions, which was particularly important for those who could not read or write, minimizing issues of comprehension and misinterpretation. Focus group discussions enabled participants to collaboratively discuss and critically analyze the research problem. This method allowed the researcher to capture general opinions on the issue under study and to validate and supplement the information obtained from individual interviews. Questionnaires and observations were further employed to enhance validity and complement the data collected through interviews.

### Study population

The study population for this research focused on street children in Lusaka, which was estimated at 2,000 as of December 2018 (Musika, 2018) as cited in UNICEF (2021)). For the purposes of this study, the population was categorized as follows: children living on the streets full-time, those currently in institutional care undergoing the process of reintegration, and those who had already been reintegrated into their families and communities.

### Sample size

The study had a sample size of 56 participants, determined based on participant availability, willingness to participate, and the time frame for data collection. The sample was drawn from two organizations working with street children, namely Fountain of Hope and Mtunzi Children's Home, as well as from street children in the Central Business District of Lusaka. The sample distribution included: 4 caregivers (2 from Fountain of Hope and 2 from Mtunzi Children's Home), 2 guardians of former street children receiving institutional care at Fountain of Hope, 23 children in institutional care (16 from Fountain of Hope and 7 from Mtunzi Children's Home), 9 children living on the streets of the Central Business District, and 2 former street children who had graduated from institutional care at Mtunzi Children's Home and were living independently. Two focus group discussions were conducted: one with 10 street children from the Central Business District of Lusaka, and another with 6 children

in institutional care at Fountain of Hope. This sample size was determined primarily by participant availability and accessibility.

### Sampling design

A non-probability sampling technique, specifically convenience sampling, was used. Participants were selected based on their availability, accessibility, and willingness to participate in the study.

### Data analysis

The data collected from all interviews were transcribed, and observations and questionnaire responses were coded to identify prominent themes, ideas, and patterns. After coding the narrative data, it was analyzed using SPSS to obtain frequencies for each theme. This was done to determine the extent to which a particular theme or factor was favored or not.

### Ethical considerations

The researcher obtained consent from the two organizations, namely Mtunzi Children's Home and Fountain of Hope, to collect the necessary data from the children and caregivers under their care. The organizations also served as a link to both former street children who had been reintegrated into the community and those who were still living on the streets.

## RESULTS

Here are some results from the thesis corresponding to each of the subheadings discussed in the discussion. Results for objective 1: Factors that lead to street children's preference for the streets to reintegration. To determine factors that made street children prefer the streets to reintegration, the study explored reasons why children in the first place go to the streets. Furthermore, the study looked at the centres that children had stayed in and the reasons they left the particular centres. Results for objective 2: Factors that have led to ineffectiveness of current programs in removing children from the streets. To explore this, a focus group discussion was conducted with children on the streets. Additionally, individual interviews explored the general view on why children leave centres. The interviews also tried to find out what centres the children on the streets knew about. Furthermore, caregivers at centres responded to a questionnaire on their intervention. Results for objective 3: Factors of Interventions that would be effective in removing children from the streets. To determine these factors, the study explored aspirations of children in both institutional care and on the streets, as well as what would enable them achieve their aspirations. The study further explored children's views on what they enjoyed at the centre and what they wished to be added to the centre. Furthermore, reasons why some children preferred centres were also examined. Additionally, results from focus group discussions with children at a centre, interviews with parents of children in institutional care, and caregivers also brought out views on interventions that would be effective.

## DISCUSSION

### Factors that lead to street children's preference of the streets to reintegration

The results presented in Table 1 indicate that 26.09% of children in institutional care cited reintegration as a reason for leaving the particular center they had previously stayed in. This suggests that even after reintegration, some children still return to the streets and may end up being taken in by another center:

*Care giver: children leaving to go back to the streets are a daily thing. A month ago, of the 67 children we got from the streets we were only left with 40 three weeks down the line, the rest went back to the streets.*

In examining factors that make street children give preference to the streets over reintegration, several key issues are highlighted. The streets are preferred when conditions that pushed the child to the streets are still in existence. Some push factors that compel children to the streets, if not addressed, contribute to the resistance by children to reintegration. Among the children in institutional care, 34.78% cited poverty, 26.08% cited abuse, 52.2% cited family conflict as the reason for becoming a street kid. Among children living in the streets, push factors such as poverty and abuse were also given as reasons for becoming a street kid. 22.2% cited poverty, 11.1% cited abuse, and 44.4% cited family conflict. Therefore, poverty, abuse, and family conflict are some of the push factors that compel children to the streets. The presence of these conditions in institutions, manifested in different forms such as conflict with friends, mistreatment from caregivers, and gaps in the provision of basic needs were cited as a reason for leaving a particular centre back to the streets among children in institutional care. 4.35% cited conflict with friends as a reason for leaving the centre, and 8.70% cited mistreatment from caregivers as a reason for leaving the centre. These factors were similarly noted by children on the streets, with 44.4% citing conflict with friends as a reason for leaving a centre, and 11.1% citing mistreatment from caregivers as a reason for leaving a centre. Further, the focus group discussion by children in the streets and interviews by former street children showed that the presence of some push factors during reintegration made them non-responsive to the intervention of reintegration. This finding is in line with what Mokomane and Makoae (2015) established in South Africa, that implemented programs did not take into account the varied and interconnected factors that impelled children to the streets and thus they did not adequately deal with the risks and opportunities for street children.

*Girl 9 in institutional care: I left the other centre because one of the care givers used to use abusive language*

**Table 1.** Factors contributing to children's preference for street life.

Factor category	Specific factor	Children in institutional care (%)	Children living on the Streets (%)
Push factors (original causes of street life)	Poverty	34.78	22.2
	Abuse	26.08	11.1
	Family conflict	52.2	44.4
Push factors within institutions	Conflict with friends	4.35	44.4
	Mistreatment by caregivers	8.70	11.1
	Reintegration as reason for leaving	26.09	0
Pull factors	Making money	56.52	77.8
	Peer pressure	43.48	100
Behavioral adaptation street to life	Satisfying addictions (drugs, sex, alcohol)	21.74	33.3
	Failure to adapt to strict rules	21.74	22.2
Reintegration process	Preference for staying at the centre rather than home	69.6	77.8

*towards us. Street girl: they beat a lot at that centre that is why I run away.*

Some children in institutional care preferred staying at the centre because of the belief that they would still be subjected to abuse, poverty and family conflict if they went home.

*Boy 12 institution: given a choice I would choose to stay at the centre because I know my step mother still doesn't love me up to now.*

The children in the streets also had their concerns with centres, as they cited conflict and mistreatment as factors that contributed to their leaving particular centres. Therefore, it can be concluded that the presence of push factors in the process of reintegration or after reintegration contributes to their resistance to reintegration.

*Focus group streets: the children are beaten at that centre, some of the teachers beat a lot, when one person offends then everyone faces the consequences.*

*The food we were served at the centre was not enough and they didn't provide us with clothes, we ended up staying with the same clothes over and over and this made us feel bad because we looked dirty while our friends looked clean.*

*Street boy: my friends used to fight me a lot, when my friends annoy or fight me and I beat them back, the*

*caregivers would end up beating me so I left.*

### **Pull factors such as making money and peer pressure affect children's preference for the streets to reintegration**

Among children in institutional care, 43.48% cited peer pressure as reason for going to the streets and 56.52% cited making money as reason for going to the streets. Similarly, 100% of children in the streets cited peer pressure as reason for going to the streets and 77.8% cited making money as reason for going to the streets. Further, responses by former street kids also show that making money and peer pressure are some of the high-ranking reasons or pull factors for children going to the streets. While on the street's children beg for money or do odd jobs in order to find money to provide for their needs. However, the rules at centres do not provide an opportunity or freedom for kids to find money using these and any other avenues which for some children becomes difficult to live with and thus they reject reintegration. 21.74% of the children in institutional care had left centres before because of the need to make money.

Some children are resistant to reintegration due to peer pressure from friends who view the street as better than home or a child care facility. 34.78% of the children in institutional care left a centre before due to peer pressure, and 77.8% of children in the streets left centres due to the same reason. Embleton et al. (2020) examined resilience among Kenyan street youth, noting that their

reluctance to leave the streets often stemmed from a sense of autonomy and social networks developed in street life. Therefore, these findings suggest that many children find emotional and social support on the streets that they don't feel in institutional settings, which could be critical for understanding their resistance.

*Street boy 5: we run away from the centre with my friends we just decided to come in town. Boy 4 institution: I used to run away because I used to follow group influence when they say we run away so that we smoke drugs.*

*Street girl: My friend was constantly fighting with another girl we found at the centre so we decided to just leave.*

*Girl 2 institution: I am used to having money so if I stay without money I run away from a centre.*

*Girl 1 institution: I left the centre because money was hard to find there in town money is easily found.*

*Boy 3 institution: my friend made me run away from the centre.*

Thus, it can be concluded that where there exist pull factors such as peer pressure and making money, some children are not responsive to reintegration. Not allowing children to go out to beg for money or work for money reduces their ability to buy whatever they want at a particular time and reduces their choices, which for some becomes unbearable, and they end up running from the centres during the process of reintegration. How a child adapts to street life highly influences their preference for the streets to reintegration: On the streets, some children indulge in sex, drugs, and alcohol. Once at centres, the children are not allowed to take any drugs, alcohol, or indulge in sex, which becomes a cause for those who are addicted to drugs and alcohol to leave centres. 21.74% of children in institutional care cited satisfying addiction as a reason for leaving centres, and 33.3% of children in the streets attributed their leaving centres to satisfying addictions.

*Boy 3 institution: I left the centre because I was addicted to smoking the stika (intoxicating chemicals).*

*Street girl: some of them are addicted to smoking and some miss their boyfriends and that's why they leave centres.*

*Girl 9 institution: they go back to the streets because they miss having sex with their boyfriends.*

Interviews with former street kids brought out the perspective of failure to adapt to strict rules as a reason for leaving the centre. Additionally, 21.74% of children in institutional care and 22.2% of children in the streets all cited failure to adapt to strict rules at the centre as a

reason for leaving the centres. This can be used to explain the fact that some children leave centres because the rules restrict them from satisfying their addictions.

*Boy 2 institution: I was failing to cope with my drug addiction and I would hide to smoke, go and then come back to the centre.*

*Care giver: they go back to the streets because of money and sex they are used to having sex on the street this a normal thing for them and smoking of sniff (intoxicating chemical). We don't allow that at the facility and so they go back.*

The process of reintegration: 69.6% of the children in institutional care and 77.8% of those living in the streets respectively preferred staying at the centre, which is a component of the reintegration process. This is an indication that some children do not necessarily look forward to reintegration but are comfortable with institutional care even when given the option of going home. For such children, advancing in the process of reintegration, which is reuniting them with their relatives, has forced them to leave centres or can force them to leave a particular centre, thereby negatively affecting the process of reintegration. Further, interviews with parents of children in institutional care revealed that some guardians saw institutional care as a better option for their children despite the option of reintegration.

*Girl 9 institution: I left the centre because they were taking children home and I dint want to go home.*

*Boy 3 institution: I have visited home several times but I prefer staying at the centre because I will just end up being influenced by friends at home and become spoiled.*

*Guardian: even if we have that option of reintegration, the best for the boy now is that you continue keeping him.*

*Boy 16 institution: even if I have gone home or been staying home for a while now, I still feel the centre is better for me and so I would choose the centre given a choice.*

In summary combination of unresolved push factors, appealing pull factors, difficulty adapting to institutional rules, and discomfort with the reintegration procedure drives children's resistance to reintegration. These elements highlight the multifaceted challenges of removing from street life and the need for tailored approaches in reintegration interventions.

### **Factors that have led to ineffectiveness of current programs in removing children from the streets**

In Zambia, efforts to deal with the problem of street kids are mainly centred on the reintegration of those in the streets

**Table 2.** Factors contributing to the ineffectiveness of current programs in removing children from the streets.

Factor	Indicator/Description	Percentage
Perceived effectiveness of interventions (caregivers)	Rated the intervention as very good	33.3
	Rated the intervention as good	33.3
	Rated the intervention as average	33.3
Satisfaction with intervention outcomes (caregivers)	High satisfaction	33.3
	Moderate satisfaction	66.7
Alignment of programs with children's needs (Caregivers)	Programs reflect children's needs	66.7
	Undecided on relevance of programs	33.3
	Satisfying addictions (children in institutional care)	31.5
Reason for leaving centres	Failure to adapt to strict rules (Children in institutional care)	21.7
	Satisfying addictions (street children)	33.3
	Failure to adapt to strict rules (street children)	22.2
Awareness of available centres (street children)	Awareness of Fountain of Hope	77.8
	Awareness of Carol	88.9
	Awareness of St Lawrence	77.8
	Awareness of Chisomo	88.9
	Awareness of Chikumbi	33.3
Pull and push factors (children in institutional care)	Conflict with friends	4.35
	Mistreatment by caregivers	8.70
	Misconduct	13.0
	Disatisfaction with centre life	17.4
	Missing family	13.0
	Missing friends	4.3
Pull and push factors (street children)	Peer pressure	77.8
	Conflict with friends	4.4
	Mistreatment by caregivers	11.1

as acknowledged by care givers. In this study, as Table 2 shows, one third of care givers rated their intervention as very good, one third as good and one third as average in addressing the challenge of street kids. Similarly, one third of care givers expressed high satisfaction with the outcomes of their intervention while two thirds expressed moderate satisfaction. Notably all care givers observed improvement in the lives of reintegrated children and regarded their intervention as effective in removing children from the streets. Each intervention in the reintegration process is critical to ensuring a successful reintegration of a once street child. However, there remains a possibility of a child going back to the streets at any stage of reintegration or even after reintegration due to different factors. These factors include a lack of

resources, gaps in program design, deficiencies in the reintegration process, and limited awareness among communities and children as discussed below.

### Lack of resources

Caregivers identified the lack of resources as a major barrier to implementing effective interventions. The lack of resources creates a gap that negatively affects the intended outcomes of programs that are part of the interventions and consequently the effectiveness of the interventions. The lack of resources is seen through the gap in service delivery, where the provision of essential services that are vital in the reintegration process are

omitted or not fully applied.

*Care giver 1: We have had to stop some skills and activities we used to implement because of the lack of resources. The workers need to be paid to train the children but we don't have the resources from donors. Sometime we have to reduce provision of certain things such as clothes, shoes if donor fund is reduced.*

*Caregiver 1: The number we admit in the facility depends on the donor fund available. If the money is not there, we don't recruit more, we reduce or stop. And wait for some to graduate then we can replace them. Inadequate equipment is a challenge in training the children.*

*Care giver 2: We sometimes have challenges feeding the children, things to use, we don't have washing powder, clothes, and other things to give to the children. Sometimes we don't have a donor to donate the owner of the facility may not provide adequate money*

*Care giver 2: resources are a hindrance to achieving some intended objectives, because reintegrating a child requires money. Sometimes you want to reintegrate a child but you have no money.*

Therefore, it can be concluded that the lack of resources affects the provision of critical components necessary for reintegration. This may lead the children to give preference to the streets over reintegration, consequently making interventions ineffective in removing children from the streets.

### **Program design deficiencies**

Programming of interventions lacks or offers very little of some critical components that are a necessity to successful reintegration, particularly in addressing the psychological, behavioural, and mental health needs of street children. 3/3 caregivers of institutions expressed the need to adjust the interventions for improved outcomes. Caregivers also highlighted some affected outcomes and how interventions can be improved. Mental, behavioural, and psychological factors come out strongly as reasons why children leave centres. From the results in Table 2, children in institutional care highlighted these factors through their responses on why they left centres. 31.5% cited satisfying addictions, 21.7% cited failure to adapt to strict rules. These factors are also highlighted in the reasons for leaving centres given by the children living in the streets, where 33.3% cited satisfying addictions and 22.2% cited failure to adapt to strict rules as reasons for leaving a centre.

*Care giver 2: because the children go through a lot of things in the streets their hearts are something else. They are aggressive, rude, they smoke Bo stick (intoxicating*

*substance) and have mental issues.*

Interventions pay little attention to this component of programming. While activities like sports and Arts were well integrated into programs, mental health support is often inadequate and left to caregivers without professional expertise.

*Girl 5 institution: if more counselling was conducted more often it would really help for those who come from the streets the counsellors come but not too often.*

*Former street kid: when we are in the streets, we adopt a certain state of mind and look at life differently so centres should have counselling that transforms the mind because the resist staying at the centre because of their state of mind.*

*Girl 7 institution: they fail to cope with the rules at the centre which restricts the lifestyle they are used to in town such as sleeping with boys. When we mess up the staff have the right to beat us because any place has rules but some find it hard to cope.*

*Caregiver: There is an organisation that deals in counselling that comes to help out with counselling services from time to time.*

*Caregiver 1: Some children who don't think there is more to their lives leave the centres but some after counselling are convinced some just go back to the street.*

*Caregiver: The ones we have a problem with are the ones coming from the streets because they still have the Bo stick (intoxicating substance) in their heads they need counselling.*

*Caregiver: We the caregivers take them through counselling as we are also trained in a component of counselling.*

It can be concluded that children from the streets face behavioural, mental, and psychological issues that make them unable to cope with the reintegration process. Without addressing the psychological and emotional challenges faced by street children, reintegration programs remain less effective, often resulting in children returning to the streets.

### **Gaps in the reintegration process**

Interviews with caregivers revealed that some children leave centres to go back to the streets and some go back to the streets after reintegration. The reintegration process with its different pathways and interventions is rich and can improve the outcomes. However, organizations fail to

implement some components of the process, which results in premature reintegration (this entails that the child has not gone through all the necessary components needed for their reintegration) and consequently the child going back to the streets after reintegration or the child leaving a centre in the process of reintegration. The gaps can be seen in the aspect of empowerment. Reintegrated children have sometimes gone back to the streets because of the fact that the reintegration process did not address some factors of empowerment, such as the family's financial capacity to take care of the child's basic needs and the sustainability of this capacity. Families need to be empowered not only financially but psychologically, as this will increase resilience in families and children to factors that impel children to the streets, such as poverty, as well as help the family know how to relate with the child.

*Caregiver 2: a significant way of empowering these children is empowering those taking care of them.*

*Caregiver 4: the only time a child goes back to the streets after reintegration is when there is premature reintegration. That is when the child has not gone through all necessary steps to rehabilitate them*

*Caregiver 3: Social welfare sometimes just want the child to be integrated without checking and making sure the children's situation at home is conducive.*

Additionally, inadequate monitoring and evaluation at different stages of the reintegration process and post-reintegration hinders the detection of certain anomalies such as family conflict and poverty, which, if not addressed, drive children to the streets.

*Caregiver 3: Parents are given empowerment fund when a child is reintegrated and it's up to them to put it to good use.*

*Street boy 5: I left the centre because I was reintegrated home with a relative who later took me back to my father, but because of the hunger situation at home I run away again.*

*Girl 2 institution: I left home after reintegration because they used to abuse me a lot sending me to the fields early in the morning.*

*Street child 3: I left home because my siblings call me a street kid.*

*Care giver 2: we work hand in hand with social welfare so they takeover follow up on reintegrated children and sometimes they give us feedback.*

Thus, it can be noted that the gaps in the reintegration process are a factor that hinder effectiveness of interventions.

### **Lack of awareness**

Lack of awareness about programs by the poor and vulnerable members of the community has impacted the effectiveness of interventions. Some members of the community and the street children themselves lack awareness about empowerment programs and preventive programs that are part of these interventions. Interviews with children on the streets of centres they knew about revealed that 77.8% knew about Fountain of Hope, 88.9% knew about Carol, 77.8% knew about St Lawrence, 88.9% said they knew about Chisomo, and 33.3% knew about Chikumbi. Even though the statistics show that most children knew about the existence of centres, this information also reveals that there was a fraction of this population that did not know about the existence of centres. However, if the goal of interventions is to remove children from the streets, then it is cardinal to reach out to each and every child on the streets. The goal is one that requires that the information on the existence of centres and organisations taking care of street children is known. This lack of awareness could be a factor as to why some children have been unable to get the help they need from interventions and the reason some go to the streets and remain on the streets.

*Boy 11 institution: I can't clearly remember how many years I stayed in town as a street kid but I never knew any centre or even their existence.*

*Street boy 2: I have heard about some centres from friends but I haven't been to any centre because I don't know where they are located and when I ask my friends, they refuse to take me otherwise I would like to be at one.*

*Girl 3 institution: after my parents died, I was left with nowhere to stay and was not aware of such facilities as centres.*

*Street boy 7: I have not heard of any place they keep street kids.*

*Street boy 8: I am not aware of any of the organisations taking care of street children.*

Therefore, it should be noted that the ineffectiveness of interventions can sometimes be owed to the fact that the interventions are not adequately known to the people who should be beneficiaries. For interventions to achieve their goal of removing children from the streets, it is crucial to ensure that all street children and their communities are informed about available programs. Outreach efforts must be intensified to bridge the gap in awareness.

### **Lack of a clear strategy on how to address some pull and push factors**

Factors such as mistreatment by caregivers, peer

pressure, making money, misconduct, missing family, missing friends, and conflict with friends were cited as reasons why children leave centres. Children in institutional care highlighted these factors through their responses on why they left centres. 4.35% cited conflict with friends, 8.70% cited mistreatment, 13% cited misconduct, 17.4 cited dissatisfaction, 13% cited missing family, and 4.3% cited missing friends. These factors are also highlighted in the reasons for leaving centres given by the children living on the streets, where 77.8% cited peer pressure, 4.4% cited conflict with friends, 11.1% cited mistreatment from caregivers. The factors have been further highlighted in the focus group discussion by children on the streets. Lack of a clear strategy by centres on how to deal with these and other factors has led to ineffectiveness of interventions as children leave centres owing to these factors. In their research, Benítez and Ruggerio (2018) revisited cases across Latin America, documenting how poor living conditions and abusive practices within institutions discouraged street children from staying in rehabilitation centres. They highlighted that children with prior negative experiences in institutional care were more likely to resist subsequent interventions. Therefore, it is very important for clear guidelines and standards on how to address each of these factors, and this should be made known to both children and caregivers to avoid misinterpretation and overstepping of boundaries.

*Boy 11 institution: I wanted to run away because I became home sick and missed my parents. Focus group Street: provision of food does not reflect a person's heart; someone can offer you food but if they don't have a kind heart how do you expect someone to stay.*

*Boy 7 institution: I run away from the centre because I missed a friend, I went with to the centre who run from the centre.*

*Boy 6 institution: I got into a fight with a friend but they dint sit us down to resolve our difference or hear us out, we simply were told to leave the centre.*

*Boy 22 institution: sometimes the guys leave especially if they are being kept in a brutal manner*

### **Focus on conventional methods of helping street kids**

Interventions have not been effective because of too much focus on conventional methods of helping street kids. Reintegration has been viewed as the best way of helping street children, and all programs and activities have been tailored towards that goal. This fails to capture a particular group of street children who feel they can still live a meaningful life outside reintegration. 2/3 care givers agreed to interventions reflecting the children's needs,

while 1/3 was not decided. 2/3 caregivers agreed that programs met street children's needs, while 1/3 was undecided. However, it can be argued that this was not the case as some of the children's aspirations, such as entrepreneurship and farming, were not part of those explicitly reflected in the activities of institutions.

*Boy 6 institution: I really would like training in agriculture, and to be given land to cultivate.*

*Boy 4 institution: I love football and I would be happy if the centre helped by connecting me to a football team.*

*Street girl 2: I would like to be helped with capital for business Street girl 1: I would like to be in performing arts like dancing.*

*Caregiver: Removing a child from the streets starts from the mind as they are some children in the streets but because they think differently, they are able to support themselves without anyone noticing they are street kids.*

### **Inadequate facilities**

While a number of children run away from facilities. It is also true that the facilities that are available are not enough to accommodate the large number of street kids on the ground. Facilities are only able to take in a specific number of children that the facility can accommodate.

*Street girl 2: we tried going to one centre but we were told that the centre was full and at another centre we were told that they only accommodate boys.*

*Caregiver 2: because of the mandate we were given to remove children from the streets due the Corona Virus Pandemic. We had to improvise and turn some classes into rooms in order to accommodate the new number. But what will happen when schools resume?*

From the discussion, it can be concluded that many factors affecting the effectiveness of interventions relate to the availability of resources, the appropriateness of the intervention's design, and the extent to which it engages the children themselves.

### **Interventions that would be effective in removing children from the streets**

The following factors, as found in this study, should be considered for the effectiveness of interventions to remove children from the streets.

#### **Aspirations of children**

Programs and activities that speak to the aspirations of

children and the assistance that they need are pivotal for successful interventions. Interviews with children on the streets and in institutional care revealed that they had aspirations they wanted to achieve. Children in institutional care aspired to be doctors, pilots, lawyers, accountants, farmers, flight attendants, social workers, engineers, entrepreneurs, soldiers, soccer players, and musicians. Children living on the streets revealed that they aspired to be in the performing arts, nurses, entrepreneurs and soldiers. Programs if appropriately designed according to the children's aspirations and needs have a great influence in enticing children to remain at centres thus enabling them to go through the full reintegration process. Therefore, there is a need to assign thematic areas to the different child care facilities, with children being assigned to centres that match their aspirations. This will ensure that programs offered by institutions are able to reflect the aspirations of street children.

### **Recreational activities**

Interviews with children in institutional care revealed that they enjoyed activities such as arts and sports. Table 3 shows that 56.5% of children enjoyed sports, while 52.2% enjoyed arts. This is an indication that they appreciated their inclusion. Activities that take place in centres are motivating factors as to why some children remain at the centres. These activities play a critical role in rehabilitating children and making them less attracted to street life. Table 4 shows the results from observation of living conditions in centres.

*Caregiver: Those with talent really manage to stay at the centre.*

However, it can be noted that there was a need for more variety of activities by the children, as 21.7% recommended more sports options at the centres while 17.4% suggested that centres should include more exposure in creative arts. This indicated that there was a need to expand the scope of activities offered in institutions so as to capture the interests of more children.

*Street boy 6: I love activities such as judo, karate. Boxing*

*Boy 6 institution: it would be good if they can include more sports like acrobatics.*

*Boy 12 institution: I would like if more sports were added such as netball and volleyball because at the moment there is just football.*

*Former street kid: they need activities that can keep them busy to forget about the life in town. My talent has taken me far and kept me at the centre.*

Therefore, interventions would improve outcomes if they added more activities that would ensure the inclusiveness of more children. It is important that programs and activities that the children enjoy such as sports and various forms of art are part and parcel of interventions to assist in removing children from the streets and that these are manifested in various forms that are able to capture the interests of children.

### **Aspects of gender, age and capabilities**

There is a need for interventions to consider the dynamics of age, gender, and capabilities in their programming. These parameters can be deciding factors as to whether a child is able to cope with the different processes of reintegration successfully. It was found that both centres accommodated children of different age ranges, one of the centres was accommodating males only, and the other was accommodating both males and females. The maximum age accepted by one centre was 18 years, and the other centre accepted children of up to 15 years. However, with different age groups, genders, and capabilities come different qualities and characteristics, which all have to be considered in programming for street kids. The activities offered by centres, such as football and basketball, can be categorised as those mostly done and enjoyed by boys in a particular age bracket, which indicates that some girls and children in a younger age bracket may feel left out. Further, those from the streets were accommodated in the same child care facility as those from vulnerable backgrounds who have never been to the streets but were at the centre because their families were not in a position to support them. However, because these two groups are of different background which makes them differ in character, capabilities, and many other conditions, it sparks a number of issues such as favoritism, discrimination, and consequently conflict among children and caregivers. Therefore, it is very cardinal that interventions for street kids take into consideration these aspects in the design of their interventions. The focus group discussion among children on the streets suggested that there was an inferiority complex that brought about conflict among these two groups of children in institutional care.

*Street 6: they used to treat the ones who are transformed better than us who were just from the streets. For example, the apportioning of food was not fairly distributed as they used to serve themselves more than us.*

*Caregiver: we first start them on school. If the child is not good at school, we introduce them to a skill.*

### **Psychological, behavioural, mental, emotional, and mentorship aspects**

Interventions that would be effective in removing children

**Table 3.** Factors influencing the effectiveness of interventions for removing children from the streets.

Domain	Findings	Percentage
Recreational and talent-based activities (children in institutional care)	Enjoy sports activities	56.6
	Enjoy arts/creative activities	52.2
	Recommend more sports options	21.7
	Recommend more creative arts options	17.4
Reasons for resistance (children in institutional care)	Resistance due to satisfying addictions (drugs, alcohol, and sex)	82.6
	Failure to adapt to strict rules	78.3
	Peer pressure	47.8
	Need to make money	56.5
Reasons for resistance (children on the street)	Need to make money, peer pressure and satisfying addictions	77.8
	Failure to adapt to strict rules	44.4
Reasons for preferring centre's (children on the streets)	Prefer centres due to the provision of education	33.3
	Prefer centres due to the provision of basic needs	22.2
	Prefer centres due to the provision of being with friends	11.1
Reason why children leave centre's	Conflict with friends (children in institutional care)	8.7
	Mistreatment by caregivers (children institutional care)	13.0
	Mistreatment by caregivers (street children)	44.4

**Table 4.** Results from observation of living conditions in centres.

No.	Observation
1	Shared dormitory accommodating all ages
2	Common television entertainment for all ages
3	Sports played by older boys in the centre
4	Chores done by children in the centre
5	Bed per child

from the streets are those that would be able to address the psychological, behavioural, emotional, and mental health needs of children and provide them with some mentorship, as most of the factors contributing to the resistance of children to reintegration are mental, behavioural, and psychological. This is also reflected in the general views given by children in institutional care, where 47.8% cited peer pressure, 56.5% cited the need to make money, 82.6% cited satisfying addictions to include drugs, sex, and alcohol, while 78.3% cited failure to adapt to strict rules as reasons for resistance. Children on the streets shared similar challenges on why they left centres, with 77.8% citing the need to make money, peer pressure, and

satisfying addictions, while 44.4% cited failure to adapt to strict rules. Thus, there is a need for intervention to include an intensive component of counselling, rehabilitation and mentorship that will take care of the children's psychological, emotional, and mental health needs as highlighted above. A similar observation was made by Zarezadeh et al. (2019) in Iran, who found that substance abuse was often a significant factor among street children, with many expressing reluctances to leave the streets due to the lack of addiction support services in rehabilitation centres. Therefore, addressing addiction issues directly can thus enhance the effectiveness of removal interventions. Data collected indicate that the

children on the streets preferred to be at the centre because of the provision of education and basic needs with 22.2% preferring the centre because of provision of basic needs, 33.3% preferring the centre because of provision of education, and 11.1% preferring the centre because of being with friends. Those in institutional care preferred the centre for similar reasons. However, while the children find most of the things, they would like to be assisted with at the centres they visit some still end up leaving or fail to adjust due to other factors such as addictions to drugs, sex, alcohol, making money, peer pressure and others as already highlighted. Therefore, mental, behavioural and psychological support will enable them to build resilience and to fully benefit from the educational and other support offered by child care facilities.

*Street boy 2: I would like to be assisted with some of the challenges I go through like finding food, school, stopping the smoking of stika (intoxicating substance) and begging for money.*

*Boy 12 institution: Some children left the centre because of the presence of bullying that existed. And others were addicted to drugs but because of the rules here at the centre that forbid drugs they failed to cope.*

*Street girl: many leave especially because they are addicted to the stika and some because of their boyfriends.*

*Focus group Street: the children are used to making money and smoking drugs so they fail to stay at the centre.*

*Boy 7 institution: we don't have much freedom at the centre so others want to be where they have freedom to do whatever they want.*

*Boy 6 institution: these people can be helped if their mind is matured because even if someone is mistreated they can manage to stay.*

*Boy 5 institution: the reason why the others leave is because their mind is used to the drugs Boy 4 institution: those who run away from the centres because of addictions can be assisted with counselling*

*Boy 3 institution: giving them some freedom would help them to stay in centres.*

*Boy 22 institution: it's hard to quit drugs after you are taken out of town even, I struggled with it and I can't say I am completely rehabilitated.*

### **Team building activities**

As it has been highlighted, some children have left

centres due to conflicts and misunderstanding they have with friends and caregivers. 8.7% of children in institutional care cited conflict with friends as to why they left child care facilities, 13% cited mistreatment from caregivers. Similarly, 44.4% of children on the streets cited mistreatment from care givers as to why they left centres

*Girl 6 institution: there is no unity; we quarrel a lot, stealing from each other so I would rather be at home if I had a choice.*

*Street boy 3: the old children at the centre used to discriminate against us and call us street kids.*

*Street boy: I don't want to go back to the centre because they steal a lot.*

*Girl 2 institution: I left centre because the caregivers used to use abusive language and remind me of my bad past.*

*Street boy 5: I left the centre because there was a care giver who was bad hearted.*

*Caregiver 2: Sometimes the attitude of the children is a challenge as they may even insult you but because you are gifted you just ignore and understand what is happening to the child psychologically.*

*Caregiver 3: The children fight a lot among themselves*

*Caregiver 2: when a child comes from the street, they won't tell you the truth but when you get to them and they see the love they tell you the truth. Working with them you need to put in love and be patient and put God first. If you are harsh to them, they run away.*

Therefore, interventions that would be effective in removing children from the streets are those that include team-building activities that foster the spirit of community and togetherness in child care facilities.

### **Monitoring and evaluation**

As established through this study, children returned to the streets during and after reintegration due to different reasons. Interventions would be effective in removing children from the streets if they strengthen the component of monitoring and evaluation during and after the process of reintegration. This approach will help identify and address challenges, ensuring that the many challenges that may pose a possible threat to the success of interventions are addressed in a timely manner. Further post-reintegration monitoring will ensure that resources allocated to families and individuals are utilized appropriately for the intended purpose thereby avoiding wastage of resources.

### **Resources**

As highlighted, a lack of resources has created

significant gaps in the implementation of reintegration interventions, reducing their effectiveness. Therefore, Interventions to remove children from the streets should have a component of resource mobilisation to ensure that all programs necessary for the success of the intervention are implemented.

*Caregiver 1: With more finances it's possible to improve outcomes.*

*Caregivers 2: Government needs to build a lot of facilities for these children and offer them skill. Government is key if they can fund programs and engage experts who have been working there. Otherwise, the money they release is very little and we just depend on well-wishers.*

## Conclusion

Based on the literature reviewed, theories applied, and the data collected and analysed, the following conclusions can be made from this study.

Child-centred factors would ensure the effectiveness of interventions in removing children from the streets. Reintegration as currently structured remains one of the best interventions of removing children from the streets as it contains almost if not all the components highlighted on effective interventions which include identification of street children, family tracing, consideration of alternative care services in a case where the child is unable to reunite with the family for various reasons, the development of the reintegration in cases where the best option is for the child to be reunited with the family, which is followed by reintegration preparation, formal family reintegration and lastly post-reintegration follow-up and case closure. However, the process of reintegration can yield more significant results if factors contributing to the effectiveness of interventions, as discussed, are fully implemented and issues that lead to ineffectiveness of interventions currently in existence are addressed. This would ensure that street children are not resistant to the interventions, and consequently, a reduction in the persistently high number of street children will be achieved as more children will benefit from the interventions.

## RECOMMENDATIONS

1) Strengthening partnerships and collaboration: It is vital for organisations working with street kids and other relevant stakeholders: As a long-term measure, it will be of great benefit for organisations working with street kids to collaborate in areas of programming that would support the process of reintegration. Additionally, they should establish a partnership with other institutions that can provide expert services that can support reintegration interventions. Examples of such organisations include the Drug Enforcement Commission, hospitals, training schools,

universities, and colleges.

2) Enhance empowerment programs: There is a need to strengthen financial empowerment to poor and vulnerable families of street children, alongside awareness campaigns addressing abuse. Also, there is a need to amplify and strengthen preventive programs in the form of empowerment and mentorship, as they help in addressing the pull and push factors that compel children to the streets. Empowerment will ensure that the children coming from these families do not resort to the streets and consequently reduce the number of street children on the streets.

3) Strengthen resource mobilization: Government and organisations should invest in the welfare of this vulnerable group by investing resources, financial and human, that would adequately help in the running of interventions. Organisations working with street kids should also explore self-sustaining income generating projects to fund their operations. This will be a sustainable way of ensuring that essential services cardinal to the success of these interventions are not lacking in institutions.

4) Developing and Implementing Policies: It is essential to create policies to guide the operations of institutions working with street children. These policies will establish standardized intervention procedures, ensuring consistency in outcomes and facilitating the monitoring and evaluation of program performance. Moreover, policy documents should comprehensively address the management of children and the operations of workers, while also considering the unique needs of street children based on factors such as gender, age, and psychological well-being.

Research has indicated that boys and girls experience life on the streets differently, necessitating tailored approaches for each gender when designing support programs. Additionally, it is important to seek the best alternatives for addressing mental, psychological, and behavioral issues among children living on the streets or in institutional care. Implementing these strategies will significantly contribute to reducing the prevalence of street children and improving their overall quality of life.

## ACKNOWLEDGEMENT

The author thanks the University of Lusaka, Fountain of Hope Association, and Mtunzi Children's Home.

## CONFLICT OF INTERESTS

The author has not declared any conflict of interests.

## REFERENCES

Adebiyi AO, Owoaje ET, Asuzu MC (2008). Relationships as determinants of substance use among street children in local

- government area in south-western Nigeria. *Official Journal of the South African Academy of Family Practice* 50(5). <https://www.researchgate.net/publication/277199896>
- Aptekar L, Heinonen P (2003). Methodological implications of contextual diversity in research on street children. *Children, Youth and Environments* 13(1). <http://colorado.edu/journals/cye>
- Benítez T, Ruggerio A (2018). Institutional abuse and mistreatment: Impacts on the reluctance of Latin American street children to remain in rehabilitation centers. *International Journal of Sociology and Anthropology* 9(8):150-162.
- Bruce ER (2014). A proposed intervention project for Zambian street girls. [Thesis]. <https://academicarchive.snhu.edu/server/api/core/bitstreams/7622097e-2295-47d0-a090-8759fb984e01/content>
- Chiwaula L, Dobson R, Elsley S (2014). Drumming together for change: A child's right to quality care in sub-Saharan Africa. <https://strathprints.strath.ac.uk/68548>
- De Benítez ST (2007). State of the world's street children: Violence. London: Consortium for street children.
- Embleton L, Ayuku D, Kamanda A, Atwoli L (2020). Resilience and adaptation to street life: Insights from Kenyan street youth. *International Journal of Sociology and Anthropology* 13(1):44-58.
- Guest E (2003). *Children of AIDS: Africa's orphan crisis*. Pluto Books. [https://www.scribd.com/document/904758032/Children-of-AIDS-Africa-s-Orphan-Crisis-2nd-Edition-Author?utm\\_](https://www.scribd.com/document/904758032/Children-of-AIDS-Africa-s-Orphan-Crisis-2nd-Edition-Author?utm_)
- Hai A (2014). Problems faced by street children: A study on some selected places in Dhaka city, Bangladesh. *International Journal of Scientific and Technological Research* 3(10):45-56.
- Integrated Regional information networks (IRIN) (2008). Government fails to break the street kid addiction. <https://www.thenewhumanitarian.org/news/2008/06/12/government-fails-break-street-kid-addiction?utm>
- Korboe D (1996). Street child study, part two: A profile of street children in Kumasi. Unpublished report commissioned by UNICEF and Response, Faculty of Environmental and Development Studies, University of Science and Technology, Kumasi 30p.
- Mokomane Z, Makoae M (2015). An overview of programmes offered by shelters for street children in South Africa. *Child and Family Social Work* 1(1):378-387.
- Mtonga J (2011). On and off the streets: Children moving between institutional care and survival on the streets. Norwegian University of Science and Technology, Faculty of Social Sciences and Technology Management. Available at: <https://pdfs.semanticscholar.org/34db/fea35ac2c5846a5c17eb5363edc8615068db.pdf?-ga=2.221456536.1005292295.1596098351>
- Ministry of Community Development and Social Services and Ministry of Sports, Youth and Child Development (2006). Reporting on Survey and Analysis of the situation of street children in Zambia. UNICEF. Available at: <https://static1.squarespace.com/static/557edb36e4b0c3993dee95d1t/57dbfedaff7c5091037c2068/1474035420421/Street+Children+Study+Zambia+18+March+2007.pdf>
- United Nations Children's Fund (UNICEF) (2021). The 2021 Situation Analysis of the Status and Well-Being of Children in Zambia. <https://www.unicef.org/zambia/media/2591/file/Zambia-situation-analysis-2021-revised.pdf>
- Push and pull factors in street life: Examining the dynamics compelling children to live on the streets. *International Journal of Sociology and Anthropology* 12(4):32-45.
- Phiri P (2015). Government, NGOs redouble efforts to reform Zambian children living on the streets. *Global Press Journal (GPJ)*. <https://globalpressjournal.com/africa/zambia/government-ngos-redouble-efforts-to-reform-zambian-street-children/>
- National assembly of Zambia (2006). Report of the committee on sport, youth and child affairs for the first session of the tenth national assembly. <https://www.parliament.gov.zm/node/3868>
- Taylor DM, Lydon JE, Bougie É, Johannesen K (2004). "Street Kids": Towards an understanding of their motivational context. *Canadian Journal of Behavioural Science/Revue canadienne des sciences du comportement* 36(1):1.
- Scanlon TJ, Tomkins A, Lynch MA, Scanlon F (1998). Street children in Latin America. *BMJ* 316(7144):1596-1600. <https://www.bmj.com/content/316/7144/1596.short>
- Strobbe F, Olivetti C, Jacobson M (2013). Breaking the net: Family structure and street-connected children in Zambia. *The Journal of Development Studies* 49(5):670-688.
- United Nations Centre for Human Settlements (UNCHS) (2000). Strategies to combat homelessness. <https://mirror.unhabitat.org/documents/HS-599x.pdf>
- Zarezaeh T (2013). Investigating the status of the street children: Challenges and opportunities. *Procedia-Social and Behavioural Sciences* 84(9):1431-1436.
- Zarezaeh Z, Hashemi F, Ghorbani M (2019). Role of substance abuse in resistance to interventions: Perspectives from Iranian street children. *International Journal of Sociology and Anthropology* 11(6):189-201.
- Zambia Statistical Agency and United Nations Economic Commission for Africa (2022). A new study for the first time reveals Lusaka's contribution to the Zambian economy. <https://www.uneca.org/stories/a-new-study-for-the-first-time-reveals-lusaka%E2%80%99s-contribution-to-the-zambian-economy>